

# AQUASPEC<sup>®</sup> FAUCETS

MODEL - Z82300-XL SERIES  
SINGLE CONTROL FAUCET



## TECHNICAL INFORMATION

---

**FLOW:** 2.2 GPM [8.3L] PRESSURE COMPENSATING AERATOR\*

**MAXIMUM PRESSURE:** 125 PSI

**MAXIMUM TEMPERATURE:** 160° F

CARTRIDGE STYLE - CERAMIC DISC MIXING CARTRIDGE WITH TEMPERATURE LIMIT STOP

\* OTHER AERATORS AVAILABLE BY REQUEST

---

**IMPORTANT** THE WATER SUPPLY LINES MUST BE THOROUGHLY FLUSHED BEFORE INSTALLATION TO PREVENT FOREIGN MATTER AND DEBRIS FROM CLOGGING AND/OR DAMAGING INTERNAL COMPONENTS AND THEREBY PREVENTING THE FAUCET FROM FUNCTIONING PROPERLY

---

**NOTE:** FOR PROPER PERFORMANCE, THE OPTIONAL 8" COVER PLATE ASSEMBLY MUST BE USED WHEN INSTALLING THIS FAUCET ON A STAINLESS STEEL SINK

---

## INSTALLATION INSTRUCTIONS

1. REMOVE SPOUT BODY (#9) FROM INTERNAL BODY (#5) BY PULLING APART.
2. SECURE GASKET (#12A) WITH ADHESIVE BACKING TO UNDERSIDE OF INTERNAL BODY (#5).  
**(NOTE: SKIP TO OPTIONAL 8" COVER PLATE ASSEMBLY INSTRUCTIONS IF COVER PLATE OPTION INCLUDED)**
3. PLACE INTERNAL BODY (#5) ONTO SINK THROUGH PRE-DRILLED MOUNTING HOLE IN SINK. ORIENT BODY WITH FLEX HOSES TOWARD FRONT AND MOUNTING STUD TOWARD BACK.
4. PLACE MOUNTING RING (#12C) ONTO MOUNTING STUD (#10). FLAT SIDE OF MOUNTING RING SHOULD FACE UNDERSIDE OF SINK. SECURE INTERNAL BODY (#5) WITH MOUNTING NUT (#12B).
5. PLACE FRICTION GASKET (#12D) OVER OUTSIDE OF INTERNAL BODY (#5)
6. PLACE SPOUT BODY (#9) OVER INTERNAL BODY (#5) AND ALIGN.
7. SECURE SPOUT BODY (#9) TO INTERNAL BODY (#5) BY CONNECTING DOMED CARTRIDGE FLANGE (#2) TO CARTRIDGE RETAINING NUT (#3). USE INCLUDED DOMED CARTRIDGE FLANGE WRENCH (#12E) TO TIGHTEN.
8. INSTALL HANDLE (#1A)
  - 8.1. REMOVE COLORED HOT/COLD INDEX (ITEM #1C) FROM HANDLE BY PRESSING OUT FROM UNDERSIDE OF HANDLE (#1A)
  - 8.2. LOOSEN SETS CREW (#1B) USING 1/8" ALLEN WRENCH.
  - 8.3. SLIDE HANDLE ONTO STEM OF CERAMIC MIXING CARTRIDGE (#4)
  - 8.4. TIGHTEN SETS CREW (#1B) USING 1/8" ALLEN WRENCH. DO NOT OVER TIGHTEN.
  - 8.5. PRESS COLORED HOT/COLD INDEX (#1C) INTO HANDLE. IT MAY BE NECESSARY TO LUBRICATE THE O-RING ON THE HOT/COLD INDEX TO FACILITATE ASSEMBLY.
9. ATTACH LAVATORY SUPPLIES TO BRAIDED FLEX HOSES (#11)
10. TURN SUPPLY WATER ON AND OPERATE FAUCET CHECKING FOR LEAKS.
11. INSTALL AERATOR INTO FAUCET AND HAND TIGHTEN INTO FAUCET SPOUT. IT MAY BE NECESSARY TO REMOVE AND CLEAN THE AERATOR AT START UP.

ZURN INDUSTRIES, LLC ♦ COMMERCIAL BRASS OPERATION ♦ 2640 SOUTH WORK STREET ♦ FALCONER NY 14733

Phone: 1-800-997-3876 ♦ Fax: 1-919-775-3541 ♦ www.zurn.com

In Canada: ZURN INDUSTRIES LIMITED ♦ 3544 Nashua Drive ♦ Mississauga, Ontario L4V1L2 ♦ Phone: 905/405-8272 Fax: 905/405-1292

## OPTIONAL 8" COVER PLATE ASSEMBLY

1. REMOVE 8" COVER PLATE ASSEMBLY (#13) FROM BAG AND LOCATE (13C) MOUNTING HARDWARE.
2. THREAD TWO STUDS (#13C) ONTO BOTTOM OF COVER PLATE (#13A).
3. REMOVE SPOUT BODY (#9) FROM INTERNAL BODY (#5) BY PULLING APART.
4. SECURE GASKET (#12A) WITH ADHESIVE BACKING TO UNDERSIDE OF INTERNAL BODY (#5).
5. ATTACH COVER PLATE (#13A) TO BASE OF INTERNAL BODY (#5) USING TWO #8-32 SCREWS (#13D)
6. PLACE COVER PLATE GASKET (#13B) ONTO BASE OF COVER PLATE (#13A) AND INSERT THROUGH MOUNTING HOLES IN SINK.
7. SECURE FAUCET ASSEMBLY TO SINK USING WASHERS (#13C) AND STAINLESS STEEL NUTS (#13C).
8. FOLLOW INSTALLATION INSTRUCTIONS 4 THROUGH 11 TO COMPLETE INSTALLATION.

## OPTIONAL HOSE SPRAY ASSEMBLY

1. REMOVE HOSE SPRAY ASSEMBLY FROM BAG AND REMOVE PLASTIC LOCKING NUT FROM HOLDER.
2. INSERT HOLDER THROUGH SINK AND SECURE WITH PLASTIC LOCKING NUT FROM BOTTOM OF SINK. DO NOT OVER TIGHTEN.
3. INSERT HOSE THROUGH HOLDER.
4. CONNECT HOSE END TO COUPLING (#15). IT MAY BE NECESSARY TO USE THREAD SEALER.

---

## MAINTENANCE

1. YOUR ZURN FAUCET HAS A HIGHLY POLISHED NICKEL CHROME PLATED FINISH. CLEAN WITH SOAP AND WATER OR A MILD CLEANER WHICH IS SAFE FOR CHROME PLATING. DO NOT USE ACIDS OR TOILET BOWL CLEANER AS THEY WILL DAMAGE THE FINISH.
2. AQUASPEC FAUCETS CONTAIN CERAMIC MIXING CARTRIDGES WHICH REQUIRE NO MAINTENANCE. TO REMOVE AND REPLACE THE CARTRIDGE:
  - 2.1. REMOVE HOT/COLD INDEX BUTTON (#1C) BY CAREFULLY PRYING LOOSE FROM UNDERSIDE OF HANDLE (#1A)
  - 2.2. LOOSEN SET SCREW (# 1B) IN HANDLE USING 1/8" ALLEN WRENCH.
  - 2.3. REMOVE HANDLE FROM CARTRIDGE STEM
  - 2.4. LOOSEN AND REMOVE DOMED CARTRIDGE FLANGE (# 2) USING FLANGE WRENCH (#12E) PROVIDED.
  - 2.5. LOOSEN AND REMOVE CARTRIDGE RETAINING NUT (#3)
  - 2.6. PULL CERAMIC MIXING CARTRIDGE (#4) BY PULLING ON STEM WHILE WIGGLING FROM SIDE-TO-SIDE
  - 2.7. INSTALL NEW CARTRIDGE USING THE ALIGNMENT PINS FOR PROPER ORIENTATION AND PROPER SEATING IN THE FAUCET BODY.
  - 2.8. REINSTALL HANDLE ASSEMBLY BY REVERSING STEPS 2.1 THROUGH 2.5.
3. TEMPERATURE LIMIT ADJUSTMENT – THE Z82300-XL FAUCET MAY BE ADJUSTED TO LIMIT THE MAXIMUM OPERATING TEMPERATURE.
  - 3.1. REMOVE CERAMIC MIXING CARTRIDGE (#4) PER MAINTENANCE INSTRUCTIONS 2.1 THROUGH 2.6 ABOVE.
  - 3.2. REMOVE RED TEMPERATURE LIMIT RING FROM MIXING CARTRIDGE.
  - 3.3. ROTATE RED TEMPERATURE LIMIT RING CLOCKWISE TO INCREASE MAXIMUM TEMPERATURE OR COUNTER-CLOCKWISE TO DECREASE MAXIMUM TEMPERATURE. RED TEMPERATURE LIMIT RING IS MARKED WITH ARROWS AND +/- TO INDICATE DIRECTION OF ROTATION AND EFFECT ON MAXIMUM TEMPERATURE.
  - 3.4. REPLACE RED TEMPERATURE LIMIT RING IN DESIRED ORIENTATION.
  - 3.5. REINSTALL HANDLE ASSEMBLY BY REVERSING STEPS 2.1 THROUGH 2.5.
  - 3.6. TEST MAXIMUM TEMPERATURE FOR ACCEPTABILITY AND REPEAT STEPS 3.1 THROUGH 3.5 IF NECESSARY.

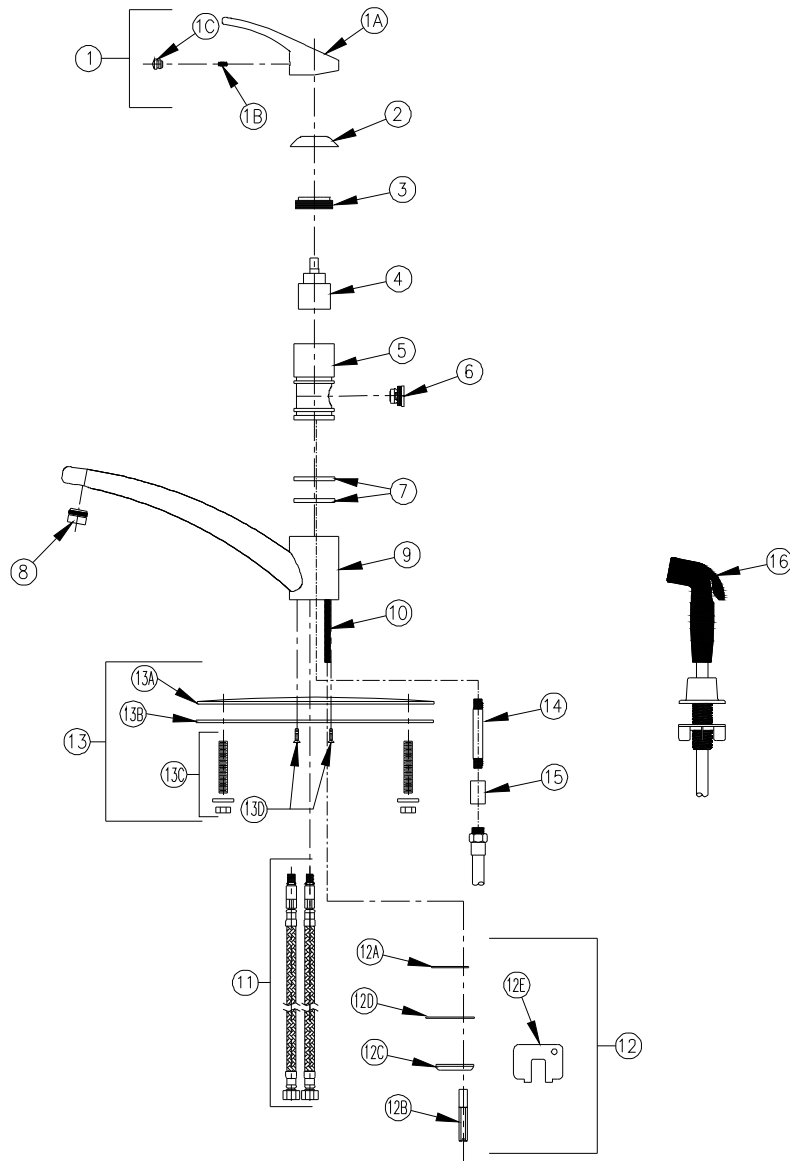

Z82300-XL-CP8-HS PICTURED

Item	Part Number	Description	Qty.	Item	Part Number	Description	Qty.
1	G63237	Single Control Handle Ass'y	1	12A	63253002	Gasket	1
1A	63232002	Single Control Handle	1	12B	63240001	1/4-20 UNC Mounting Nut	1
1B	63234001	1/4-20 x 3/8" Set Screw	1	12C	63239001	Mounting Ring	1
1C	92255001	Hot/Cold Index Button	1	12D	63254002	Friction Gasket	1
2	62797001	Domed Cartridge Flange	1	12E	63264004	Domed Cartridge Flange Wrench	1
3	62795001	Cartridge Retaining Nut	1	13	G65505	8" [203mm] Cover Plate Ass'y	1
4	63233001	Ceramic Mixing Cartridge	1	13A	65574001	8" [203mm] Cover Plate	1
5	63207001	Internal Body	1	13B	61606002	8" [203mm] Cover Plate Gasket	1
6	63243001	Diverter	1	13C	66978001	Hardware	1
7	63236222	Quad O-Ring	2		N/A	Cover Plate Stud	2
8	G63505	13/16-27 Male Aerator	1		N/A	Washer	2
9	63209002	10" Swing Spout Body	1		N/A	Stainless Steel Nut	2
10	63238002	1/4-20 Mounting Stud	1	13D	63299002	8-32 S.S. Screw	2
11	93318012	12"[305mm] S.S. Braided Hoses	2	14	65326001	Nipple	1
12	G65302	Mounting Components	1	15	65327001	Coupling	1
				16	G67903	Hose Spray and Holder	1

<b>Trouble Shooting Guide</b>		
<b>Problem</b>	<b>Cause</b>	<b>Solution</b>
FAUCET LEAKS FROM UNDER FAUCET HANDLE. ALL SUPPLIES ARE ON.	CARTRIDGE RETAINING NUT TOO LOOSE	REMOVE FAUCET HANDLE . TIGHTEN CARTRIDGE RETAINING NUT. DO NOT OVER TIGHTEN. TIGHTEN UNTIL NUT IS SNUG
NO WATER COMES OUT OF FAUCET SPOUT. ALL SUPPLIES ARE ON.	AERATOR IS CLOGGED.	REMOVE AERATOR. REMOVE DEBRIS AND REINSTALL AERATOR
WATER DEFLECTS AT AN ANGLE FROM THE FAUCET SPOUT	AERATOR HAS DEBRIS	REMOVE AERATOR. REMOVE DEBRIS AND REINSTALL AERATOR

## REPLACEMENT PARTS

SINGLE CONTROL HANDLE ASSEMBLY	G63237
MOUNTING COMPONENTS FOR SINGLE CONTROL	G65302
CERAMIC MIXING CARTRIDGE	63233001
8" COVER PLATE	G65505
HOSE SPRAY AND HOLDER	G67903