

ELC-43000

SERIES

► **Description**

Triple Station Solid Surface Lavatory System Equipped with Sloan OPTIMA® Sensor Operated Faucets.

► **Models**

- ELC-43080 Three Station SloanStone Lavatory with **ETF-80** Faucets
- ELC-43085 Three Station SloanStone Lavatory with **EBF-85** Faucets
- ELC-43100 Three Station SloanStone Lavatory with **EAF-100** Faucets
- ELC-43150 Three Station SloanStone Lavatory with **EAF-150** Faucets
- ELC-43187 Three Station SloanStone Lavatory with **EBF-187** Faucets
- ELC-43280 Three Station SloanStone Lavatory with **ESD-20080** Faucet/Soap Combinations
- ELC-43285 Three Station SloanStone Lavatory with **ESD-25085** Faucet/Soap Combinations
- ELC-43610 Three Station SloanStone Lavatory with **ETF-610** Faucets
- ELC-43615 Three Station SloanStone Lavatory with **EBF-615** Faucets
- ELC-43600 Three Station SloanStone Lavatory with **ETF-600** Faucets
- ELC-43650 Three Station SloanStone Lavatory with **EBF-650** Faucets

► **Specifications**

Triple Station Lavatory System with Sloan Sensor Operated, Chrome Plated Hand Washing Faucets with the following features:

- Lavatory constructed of Non-porous SloanStone Solid Surface Material
- Integral Overflow Drainage System
- 1¼" pop-up or flat strainer drain (by others)
- Sloan Optima Sensor Operated Faucets for hands free operation
- Lavatory System is shipped pre-plumbed with Sloan Electronic Controls for easy installation

Sloan Optima® Faucets feature:

- Splash-proof Control Module
- Troubleshooting LED Indicator Lights
- Chrome Plated Brass Spouts
- Filtered Solenoid with serviceable Strainer Filter
- Water saving 0.5 gpm/1.9 Lpm max. Aerator
- Hardwire or Battery powered

Faucet features may vary. See Optima® faucet specification sheets for details.

► **Variations**

- AB** Angle Bracket
- FA** Integrated Front Apron
- LS** Left Side Splash
- RS** Right Side Splash
- ESD** Electronic Soap Dispenser

► **Colors**

- AH** Ash
- SS** Sand
- SL** Slate
- TP** Taupe
- PL** Pearl
- JT** Jet
- JD** Jade
- AM** Amber
- IN** Indigo

► **Warranty**

3 year (limited)

► **Made in the U.S.A.**



Models ELC-43100 and ELC-43150 Shown

The New SloanStone™ Lavatory System — The Perfect Match

The performance and dependability of Sloan Optima® and the durability of Solid Surface are now combined in the SloanStone™ Lavatory System.

Hygienic and durable, SloanStone™ is stain, chemical and impact resistant. A SloanStone™ Lavatory System is easy to install and easy to maintain.

SloanStone™ Lavatory Systems can be provided with your choice of Sloan electronic Optima® faucet. The "hands-free" operation of an electronic Optima® faucet ensures hygiene while maintaining an aesthetically pleasing look that is suited for any public rest room installation.



The lavatory system is designed to comply with all applicable ADA, UFAS, Texas Accessibility Standards (TAS), and ANSI Z124.3 and Z124.6 accessibility guidelines when mounted at the standard 34" rim height.

Sloan Optima Faucets are:



This space for Architect/Engineer approval	
Job Name _____	Date _____
Model Specified _____	Quantity _____
Variations Specified _____	
Customer/Wholesaler _____	
Contractor _____	
Architect _____	

The information contained in this document is subject to change without notice.

ELC-43000

SERIES

Triple Station Lavatory System

OPERATION

As the user's hands enter the beam's effective range, the beam is reflected back into the sensor receiver and activates the solenoid valve allowing water to flow from the faucet. Water will flow until user's hands are removed or until the faucet reaches its automatic time out limit setting.



SLOANSTONE COLORS

Standard Colors

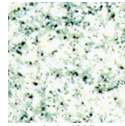

Ash (AH)



Sand (SS)

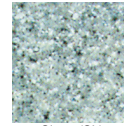

Slate (SL)



Taupe (TP)

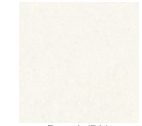

Pearl (PL)

Special Colors

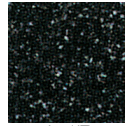

Jet (JT)

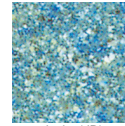

Jade (JD)

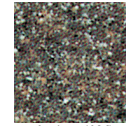

Amber (AM)

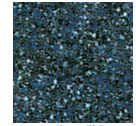

Indigo (IN)

FAUCET OPTIONS



ETF-80 and EBF-85



EAF-100 and EAF-150



EBF-187



ETF-600 and EBF-650



ETF-610 and EBF-615



ESD-2080 and ESD-2085



ESD-250

ROUGH-IN

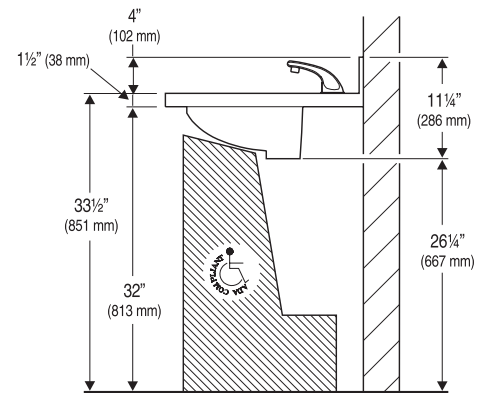
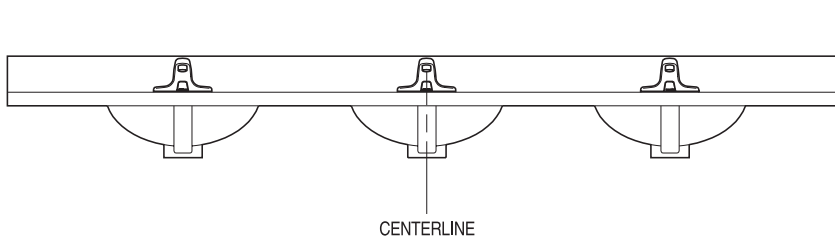
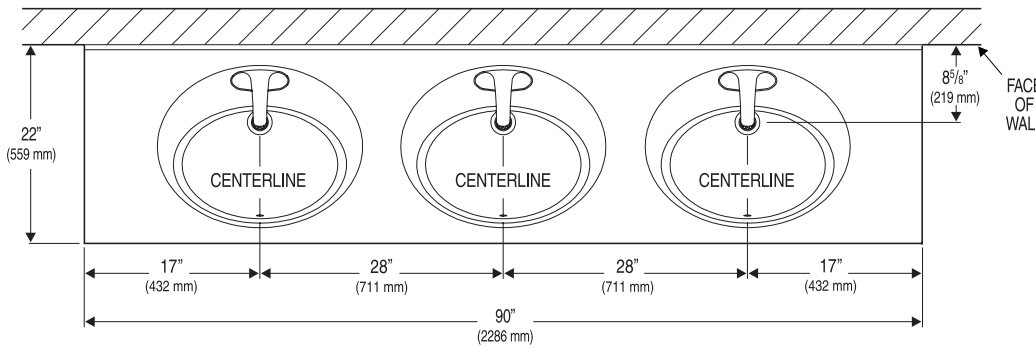

Consult local electrical codes for the mounting location of the 110/24 VAC Class 2 transformer.

For additional technical information, contact the Sloan Installation Engineering Department at 1-888-SLOAN-14 (1-888-756-2614) or techsupport@sloanvalve.com

SLOAN VALVE COMPANY • 10500 SEYMOUR AVENUE • FRANKLIN PARK, IL 60131

Phone: 1-800-9-VALVE-9 or 1-847-671-4300 • Fax: 1-800-447-8329 or 1-847-671-4380 • www.sloanvalve.com