

CODE NUMBER

33820053

DESCRIPTION

Unfiltered, Unrefrigerated, Black, DropSpot™ On-wall Bottle Filler.

DETAILS

- Mounting: On-wall
- Configuration: Bottle Filler
- Filter Option: Unfiltered (UNFIL)
- Refrigeration Option: Unrefrigerated (UNREF)
- Finish: Black (BLK)
- Full Load Amps: 1.0
- Length: 7 9/10" (201mm)
- Width: 19" (483mm)
- Height: 27 4/5" (706mm)
- Weight: 33 lbs
- Installation Location: Indoor
- Bottle Filler Water Flow Rate: Up to 1.2 gpm

POWER

- (Standard) 115VAC, 60Hz, 1A
- Provide Duplex Receptacle on GFCI Protected Circuit

FEATURES

- Touch-free sensor operated bottle filler with 20 second max run time
- ADA compliant when installed properly
- Up to 1.2 gpm fill rate for quick fill
- Swing-open cabinet provides easy access to filter
- Laminar flow water supply
- Soft ambient white light to indicate filter status
- Backlit LED light that illuminates bottle filling area when sensor is activated
- Bottle Counter Display indicates the number of 16 oz plastic bottles saved as well as the ounces of water dispensed for water consumption tracking
- Rough-in matches other manufacturers' for easy replacement

NOTES

All information contained within this document subject to change without notice.

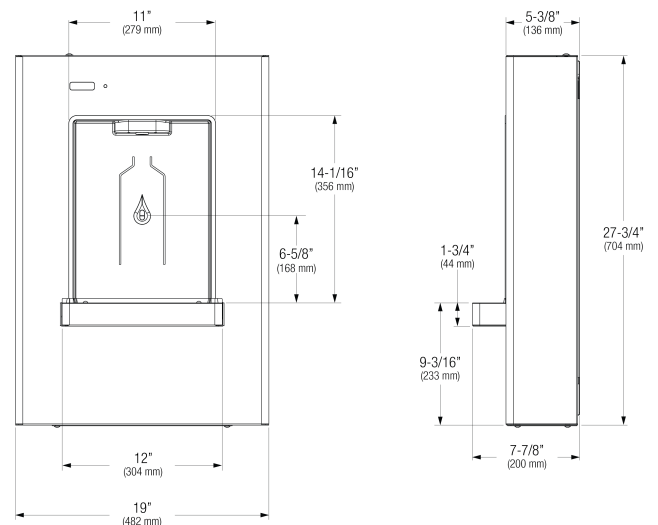

COMPLIANCES & CERTIFICATIONS



(ADA Compliant, cUPC Certified, cULus Certified, cUPC Low Lead Compliant, TAS)

ADDITIONAL COMPLIANCES

Listed to UL 399/CSA C22.2 No.120/IAPMO has listed this product to ASME A 112.18.1 / CSA B45.4, IGC 226, IGC 115, NSF-372 and NSF-61/Meets emissions requirement for the FCC/Meets Canada OBC, QBC, and other accessibility requirements

RECOMMENDED SPECIFICATION

Sloan's DropSpot™ On-wall Bottle Filler Unfiltered Unrefrigerated black powder coat. Bottle filler shall include sensor operated activation with a 20 second maximum run time. Bottle counter display indicates the number of 16 oz plastic bottles saved as well as the ounces of water dispensed for water consumption tracking. Unit shall include LED lights that illuminate the bottle filling area. Bottle filler housing construction shall be galvanealed steel with black powder coat finish. Bottle filler shall provide up to 1.2 gpm flow rate with a

Sloan 10500 Seymour Ave, Franklin Park, IL 60131

Phone: 800.982.5839 • Fax: 800.447.8329 • sloan.com

laminar flow. Cabinet door shall have swing-open mechanism, providing easy access for filter replacement.

DOWNLOADS

- [Additional Downloads](#)

ROUGH-IN

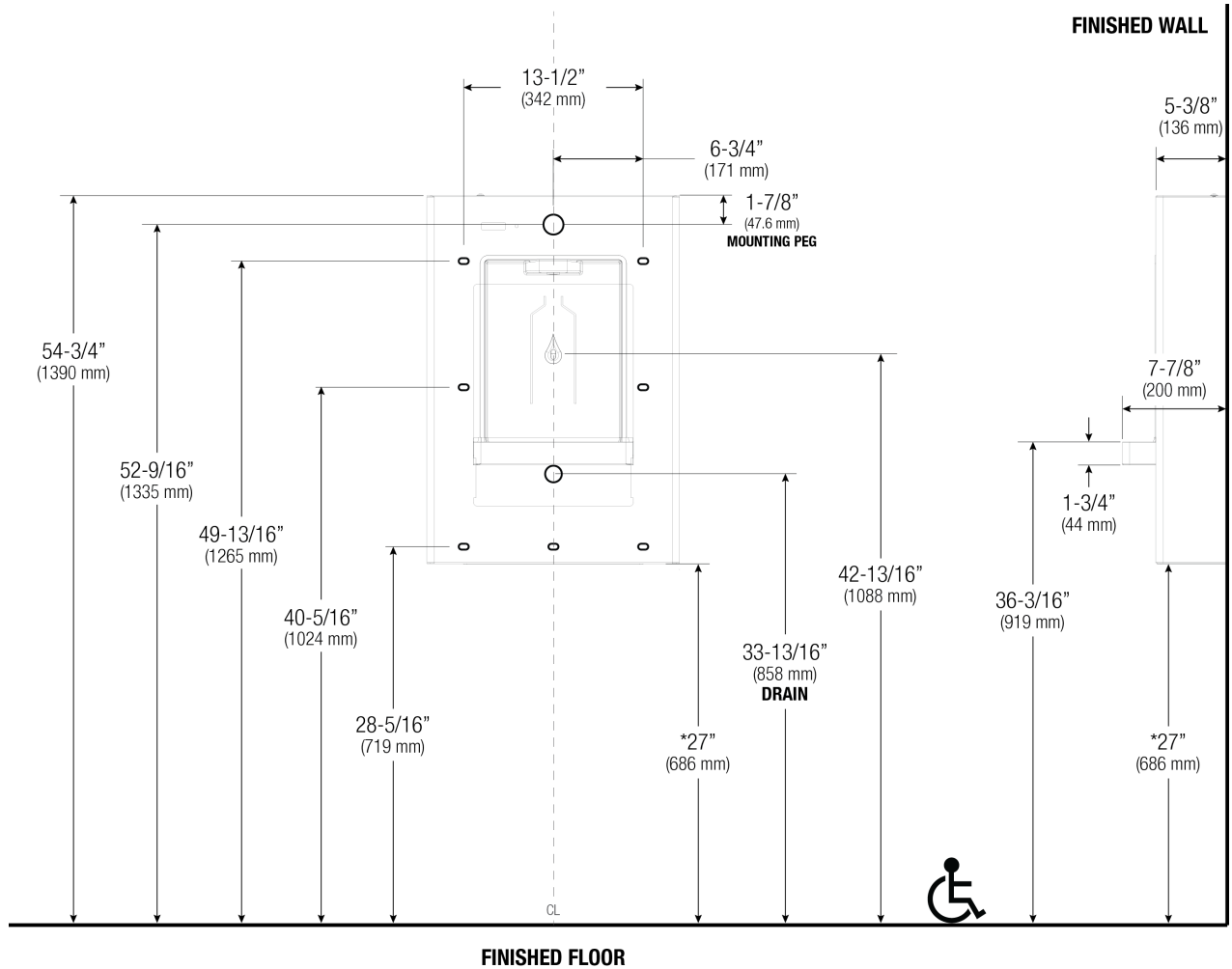

Sloan 10500 Seymour Ave, Franklin Park, IL 60131

Phone: 800.982.5839 • Fax: 800.447.8329 • sloan.com