



Technical Data

Designer Series™
COUNTER-MOUNTED
AUTOMATIC FOAM
SOAP DISPENSER

B-86_
SERIES

Specify Finish Required: B-868 Polished Chrome B-865 Brushed Nickel B-862 Matte Black



Patented

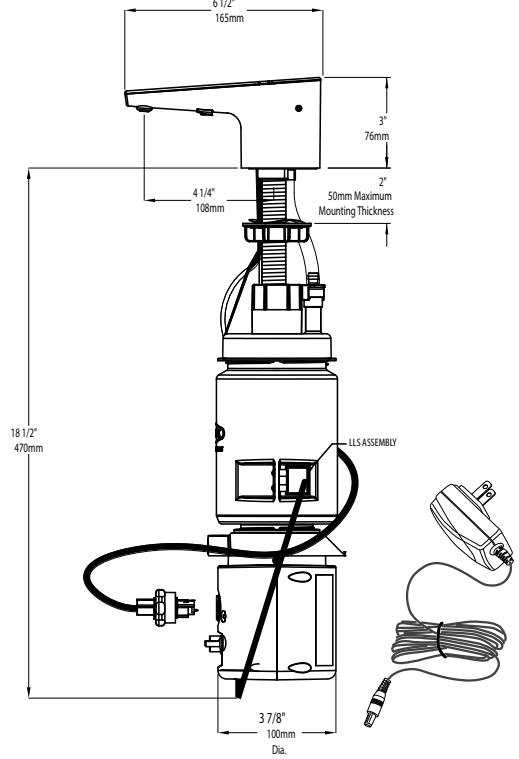
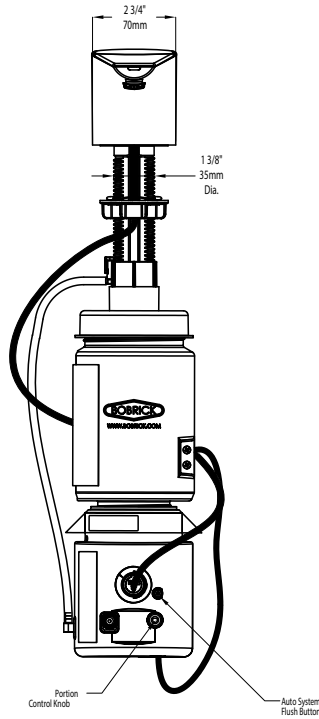

MATERIALS:

Spout and Stem Assembly — Above the counter - durable die cast zinc, available in three finishes:

Finish Type	Foam
Polished Chrome	B-868
Brushed Nickel	B-865
Matte Black	B-862

Unit equipped with a spring loaded 180° rotatable lid with concealed locking mechanism for top filling. Rotatable lid mechanism consists of metal components. Integrated to Spout are a grey plastic Dispense Tip and Activation Lens Housing. Delrin Stem connects to Plastic Bottle.

Foam Mixer Cartridge — Located inside grey nozzle tip, mixer cartridge has an integrated nylon mesh and nozzle tip is removable for mixer cartridge cleaning and maintenance.

Air Pump — Diaphragm operated electronic air pump connects to the air tube adapter and supplies air to the Foam Mixer Housing.

Foam Mixer Housing — Plastic construction connects air tube and soap outlet into a mixing chamber to create a preliminary mixture of foam.

Soap Bottle — Translucent, shatter-resistant high-density polyethylene. Capacity: 34-fl oz (1.0-L).

Pump and Soap Delivery System — A plastic Gear Pump submerged in the bottom of the Bottle, pumps the foam soap through a vinyl tube to spout.

Bottom Housing — Water-resistant, ABS plastic housing attached to the bottom of the Bottle houses the PC Board, motor that drives the Gear Pump, and the Gear Pump Housing. It includes a Portion Control Knob, Flush Button to allow for system cleaning and maintenance, a connector for the Fiber Optic cables, and Power Port.

continued . . .

Electronic Activation/Indication System — Pair of plastic Fiber Optic cables connects the plastic Activation Lenses to an IR Sensor located on a PC Board in the Bottom Housing. A third plastic Fiber Optic cable connects an LED located on the PC Board to an acrylic Lens at the tip of the Spout. All three cables are Integrated into one Fiber Optic Connector Tip for ease of installation.

Low Soap Level Indicator — Sensor attached to bottle determines when unit's soap level is low. LED light on spout to begin flashing blue when soap level is low with approximately 25% soap capacity remaining.

6V AC Adapter — 6V AC Adapter with U.S. Plug comes standard. For outlets not compatible with U.S. plugs, order Part No. 3974-58.

OPERATION:

To fill dispenser, insert tip of standard BobKey provided into opening of the concealed locking mechanism in the Spout Assembly with spout body to disengage door for quick and easy top filling. Lid will rotate open for filling dispenser with bulk **foam** hand soap only. Do not fill past midway point in funnel. Rotate door counter-clockwise to close and lock in place.

Spout will dispense foam that is generated by mixing air and foam soap. The texture of the foam can be adjusted by rotating the control dial. The texture may vary depending on the type of soap used.

LED Lights	
Flash Green →	During activation
No Light →	Standby mode and unit contains soap
Flash Blue →	Unit is low on soap
Solid Red →	Object remains in activation zone after single activation

Designers Note: Bobrick foam soap dispensers are designed to dispense commercially marketed all purpose foam hand soaps and antibacterial foam soaps that are not alcohol or iodine based. Acceptable foam soaps need to have a viscosity of less than 100cPc (centipoise).

INSTALLATION:

Unit is designed for installation into counters up to 2" (50mm) maximum thickness with 1-3/8" (35mm) diameter mounting hole. Unit may be mounted through special hole requisitioned when lavatory is ordered from manufacturer (specify hole location). Recommended mounting location is between 6" to 8" (150 to 205mm) from back wall and 3" (75mm) from the sink rim to the center of the mounting hole. Minimum 18-1/2" (470mm) vertical and 5" (125mm) diameter clearance required for soap bottle and bottom housing below mounting hole. Plug AC Adapter into wall and end plug into power port on bottom housing. Plug in USB cable from Low Soap Level Sensor into bottom of the Bottom Housing.

Designers Note: Unit is not compatible with above the counter sink rims greater than 1-1/2" W x 1" H (25 x 40mm) or 2-1/2" W x 1/2" H (65 x 12.7mm). **Caution:** Sink rim must not come into contact with activation area. For more information refer to Mounting Template included in the Installation Instructions.

SPECIFICATIONS:

Designer Series Counter-Mounted Automatic Foam Soap Dispenser shall dispense commercially marketed all-purpose bulk foam hand soaps, do not use iodine based or alcohol based soaps or sanitizers. Spout assembly shall be die cast zinc, with one of three finishes. Stem is integrated with spout and shall be Delrin plastic and accommodate up to 2" (50mm) thick counter tops. Unit shall be equipped with oversized funnel shape opening, covered by a 180° rotatable lid with concealed locking mechanism to allow for top filling. Unit shall have LED indicators to show when unit has been activated and when soap level in the bottle is low. Unit shall have IR Sensor located on PC board housed in a water-resistant plastic housing. Activation Lens shall allow for defined activation range to eliminate chance of false activation during hand washing. Unit equipped with unique two stage foam mixing chambers. Air pump delivers air to foam mixer housing, combining foam soap solution and air to form a preliminary mixture of foam. Soap is then pumped through spout where a second chamber in the nozzle tip houses a mixer cartridge with nylon mesh which delivers a rich lather of foam soap. Control Dial shall allow field adjustment of foam texture. Unit shall be equipped with an Automatic System Flush Button to allow for cleaning and maintenance. Comes with 6V AC adapter.

Designer Series Counter-Mounted Automatic Foam Soap Dispenser shall be _____ (insert model number) of Bobrick Washroom Equipment, Inc., Clifton Park, New York; Jackson, Tennessee; Los Angeles, California; Bobrick Washroom Equipment Company, Scarborough, Ontario; Bobrick Washroom Equipment Pty. Ltd., Australia; and Bobrick Washroom Equipment Limited, United Kingdom.